



TECHNICAL DESCRIPTION

**MODEL 6095-1
IRIG B DECODER/VIDEO INSERTER**

January 18, 2006

ITS MODEL 6095-1
IRIG DECODER/INSERTER

1.0 GENERAL

The ITS Model 6095-1 IRIG Decoder/Video Inserter is an IRIG B time code decoder and video insertion generator that inserts the decoded IRIG B time into an RS-170 or NTSC video signal. The time message can be positioned to any of 15 locations, nine at the top and six at the bottom as set by a front panel selector switch. The switch also has a sixteenth position which turns the message off. The unit is designed for hard mounting in an aircraft or vehicle and operates on 9 to 36 volts DC, which allows for installation on 12, 24 or 28 volt systems. A PAL/CCIR version designated Model 6095-1P is also available.



2.0 CHARACTERISTICS

2.1 INSERTED VIDEO CHARACTERISTICS

2.1.1 Alphanumeric Characters

The displayed characters are generated on a 5 x 7 dot matrix. When "Small" is selected a "dot" or pixel is two scan lines high and an equivalent measure in width. The displayed height of the characters therefore is approximately 3% of the height of the total display. When "Large" is selected the size of the pixel is doubled to four scan lines. This doubles the size of the characters both horizontally and vertically. The distance between characters horizontally is the equivalent of 3 pixels.

2.1.2 Video Insertion Method

The generated video is added to the input video using the relative or constant contrast method. This method provides a pleasing display over a wide range of original video light levels. A level set by an intensity control is added to the existing level of the original video. The contrast between the original video and the "added" generated video is therefore constant. This helps prevent wash out at the high levels and assures a non-glaring display at the low levels. An additional feature of this method is that the generated video does not obscure features on the existing video. Elements as small as one pixel can be seen through inserted video.

2.2 IRIG CLOCK

The IRIG clock is controlled by the input of the serial IRIG B signal. Once the time is established a loss of the IRIG signal will cause the 6095-1 to automatically switch to an internal real time clock which will increment the time display until the IRIG signal is re-acquired.

3.0 MECHANICAL CONFIGURATION

The 6095-1 is housed in a ruggedized 2.15 inch high by 4.5 inch wide (5.5 inch including flanges) by 6 inch deep sheet metal enclosure which is designed to meet aircraft "Safety of Flight" requirements. All circuitry is on printed circuit assemblies. Connections between PC assemblies are via mating connectors. No edge connectors are used.

Figure 1
Model 6095-1

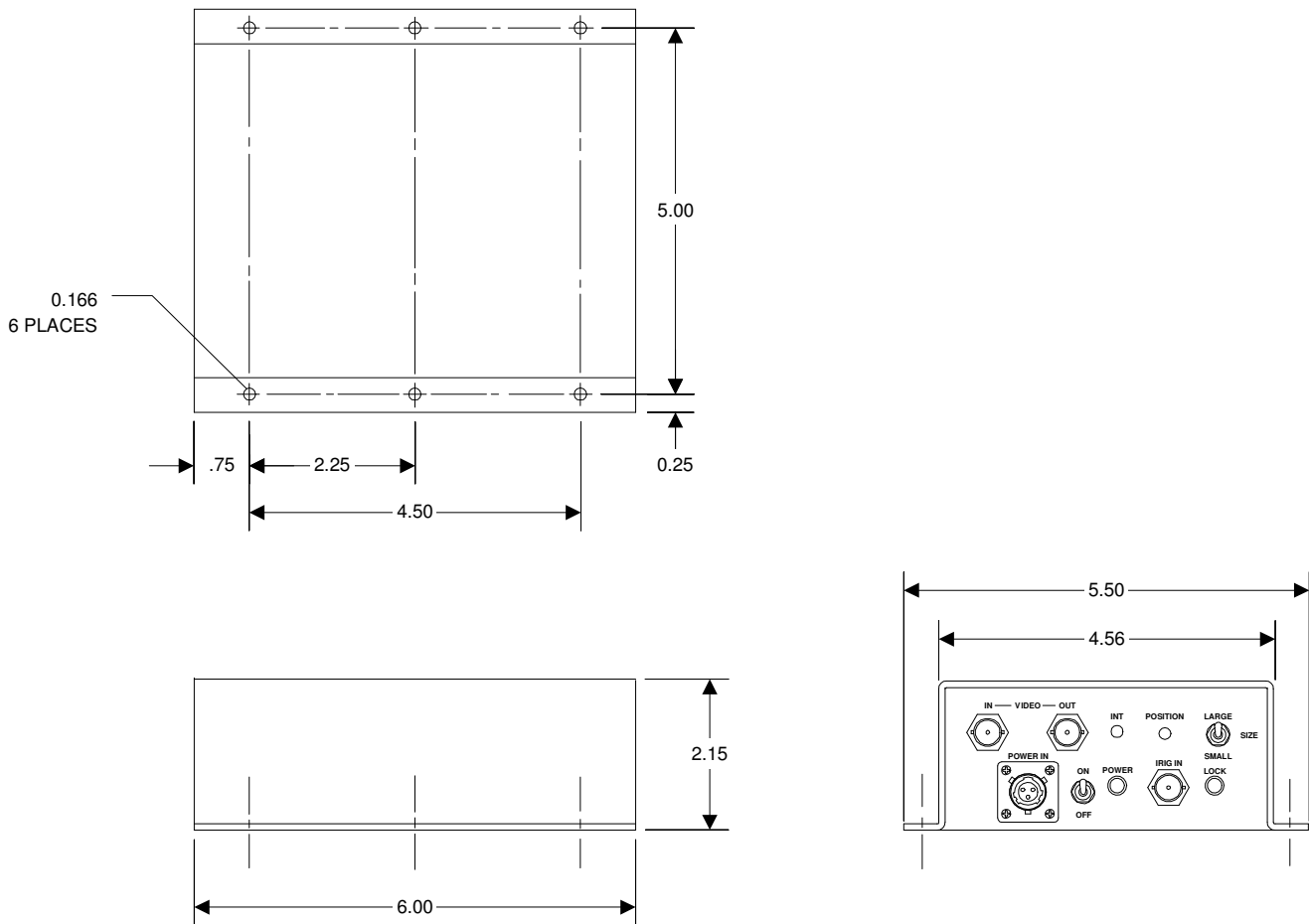

4.0 CONTROLS, INDICATORS, AND CONNECTORS (See Figure 1)

4.1	Power ON/OFF	Toggle Switch - Controls power input. LED indicator is illuminated when power is on.
4.2	Display Intensity	Rotary Potentiometer - Controls intensity of generated display for each video channel.
4.3	Position	16 Position Rotary Switches - Selects one of fifteen display locations for the IRIG time message. The 16th position turns inserted display off.
4.4	Size	Toggle Switch - Selects Large or Small inserted characters.
4.5	IRIG Lock	LED Indicator - Illuminates when IRIG signal is detected and the clock is synchronized.
4.6	IRIG In	BNC Connector - Receives serial IRIG B time signal.
4.7	Video In	BNC Connector - Receives 525 line RS-170 or NTSC video. (Model 6095-1); 625 line CCIR/PAL (Model 6095-1P)
4.8	Video Out	BNC Connector - Outputs original video with messages and symbol inserted.
4.9	Power	PT02A-8-3P Connector - Receives DC power input. Pin A +9 to +36V Pin B RETURN Pin C CHASSIS

5.0 SPECIFICATIONS

5.1	Video In	Standard 525/60 composite video 2:1 interlace, black negative per EIA RS-170 or NTSC. 75-ohm input impedance. 1.0 volt peak-to-peak, Model 6095-1; 625/50 CCIR/PAL, Model 6095-1P.
5.2	Video Out	Identical to video input except with message data added and DC restored, 75-ohm impedance (output as specified when terminated by 75-ohm load).
5.3	Video Amplifier Bandwidth	>20MHz \pm 1 db
5.4	IRIG Input	IRIG B standard Serial Time Code (IRIG Standard 200-98)
5.5	Time Display Format	0.5 milliseconds resolution, Display Format is: *DDD:HH:MM:SS.mmm.m. Note: leading asterisk is displayed when IRIG Lock is lost and display is generated from internal clock.
5.6	Internal Clock	Temperature Compensated Crystal Oscillator (TCXO). Frequency stability: 2.5 parts in 10^6
5.7	Package and Environment	
	Size:	2.15 x 4.5 x 6 inches, excluding mounting flanges. (See figure 1)
	Temperature:	0°C to 60°C ambient
	Humidity:	95% non-condensing
	Construction:	Designed to meet aircraft "Safety of Flight" requirements.
5.8	Power Input	9 to 36VDC, approximately 2.5 Watts